

Compact - IPM ID20FFX60U3S_B

Features

- UL 1557 Certified.
- Adopt the latest trench IGBT technology to get a good overall loss trade-off.
- Open Emitter on N terminal for low cost current sensing application.
- Matched propagation delay and arm shooting through prevention.
- Built-in bootstrap diodes with current limiting resistor.
- Provide a fault signal (FO pin) and shut-off internal IGBT when suffer S.C. and under-voltage faulty event.
- Provide Temperature output by analog signal.
- Provided Over temperature protection.
- RoHS compatible.

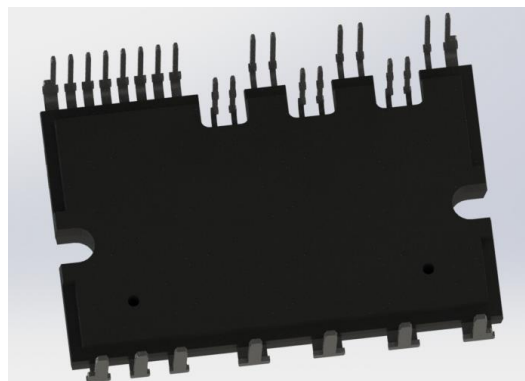
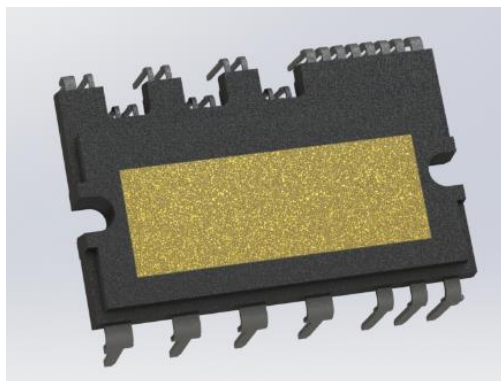
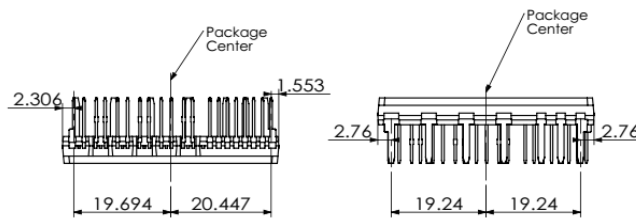
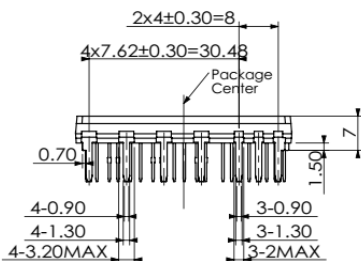
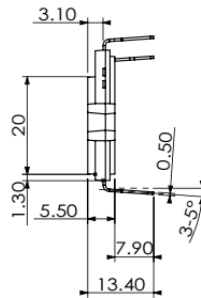
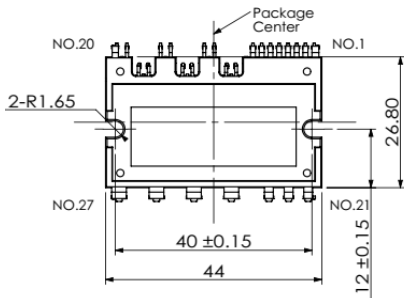
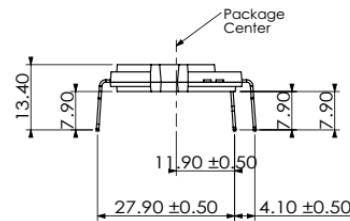
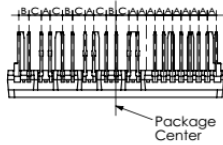

Table1: Pin Descriptions

No.	Symbol	Pin Description
1	V_{CCL}	Low-Side Common Bias Voltage for IC and IGBTs Driving
2	COM	Common Supply Ground
3	$IN_{(UL)}$	Signal Input Terminal for Low-side U Phase
4	$IN_{(VL)}$	Signal Input Terminal for Low-side V Phase
5	$IN_{(WL)}$	Signal Input Terminal for Low-side W Phase
6	V_{FO}	Fault Output Terminal
7	V_{OT}	Temperature output
8	C_{SC}	Short-Current Detection Input
9	$IN_{(UH)}$	Signal Input Terminal for High-side U Phase
10	V_{CCH}	High-Side Common Bias Voltage for IC and IGBTs Driving
11	$V_{B(U)}$	High-Side Bias Voltage for U-Phase IGBT Driving
12	$V_{S(U)}$	High-Side Bias Voltage Ground for U-Phase IGBT Driving
13	$IN_{(VH)}$	Signal Input Terminal for High-side V Phase
14	V_{CCH}	High-Side Common Bias Voltage for IC and IGBTs Driving
15	$V_{B(V)}$	High-Side Bias Voltage for V-Phase IGBT Driving
16	$V_{S(V)}$	High-Side Bias Voltage Ground for V-Phase IGBT Driving
17	$IN_{(WH)}$	Signal Input Terminal for High-side W Phase
18	V_{CCH}	High-Side Common Bias Voltage for IC and IGBTs Driving
19	$V_{B(W)}$	High-Side Bias Voltage for W-Phase IGBT Driving
20	$V_{S(W)}$	High-Side Bias Voltage Ground for W-Phase IGBT Driving
21	Nu	Negative DC-Link Input Terminal for U Phase
22	Nv	Negative DC-Link Input Terminal for V Phase
23	Nw	Negative DC-Link Input Terminal for W Phase
24	U	Output Terminal for U Phase
25	V	Output Terminal for V Phase
26	W	Output Terminal for W Phase
27	P	Positive DC – Link Input

(see figure 2, next page)

Pin Configuration

Top View

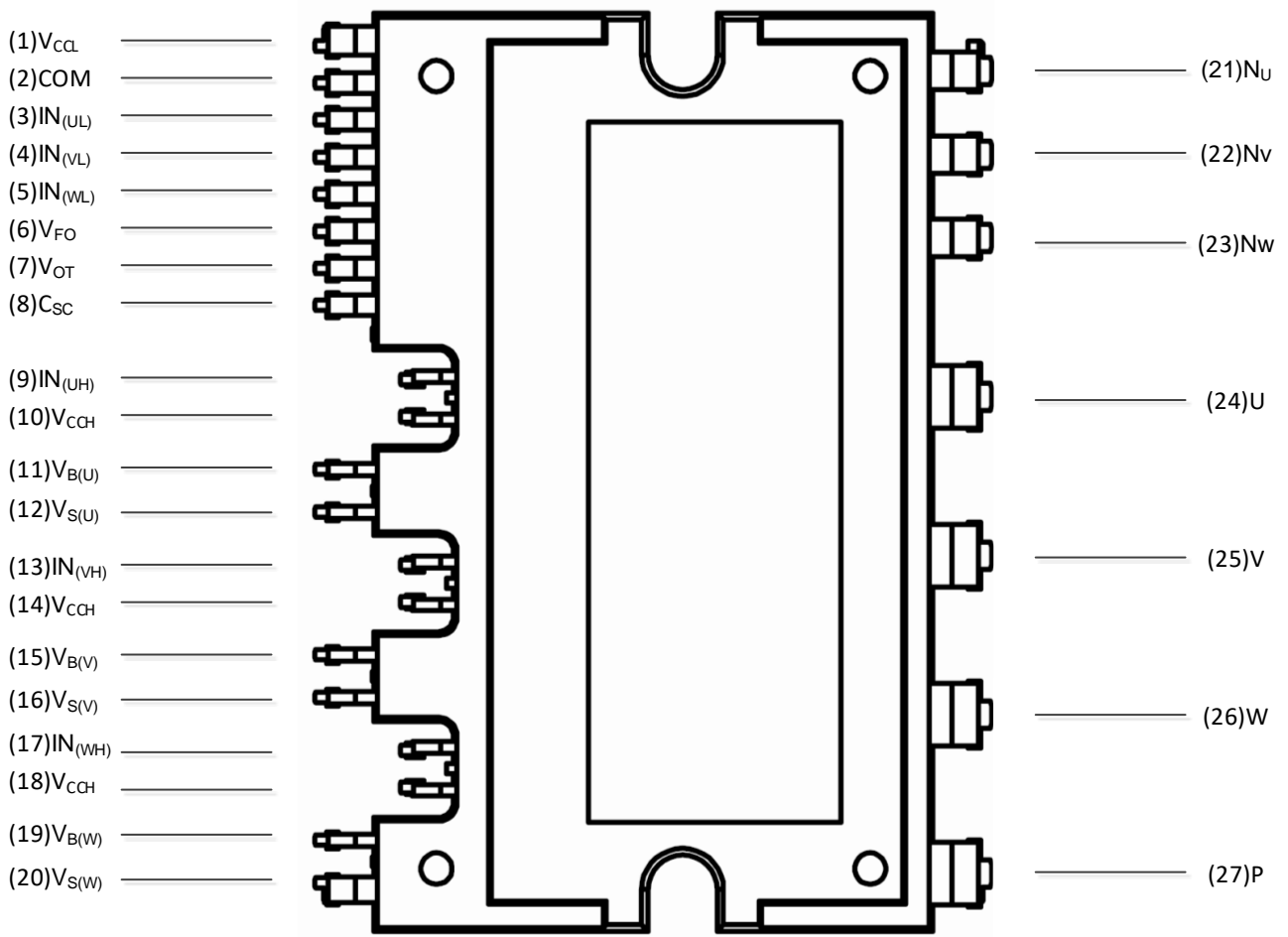

Figure 2. Pin Configuration

The IPM Internal Block Diagram

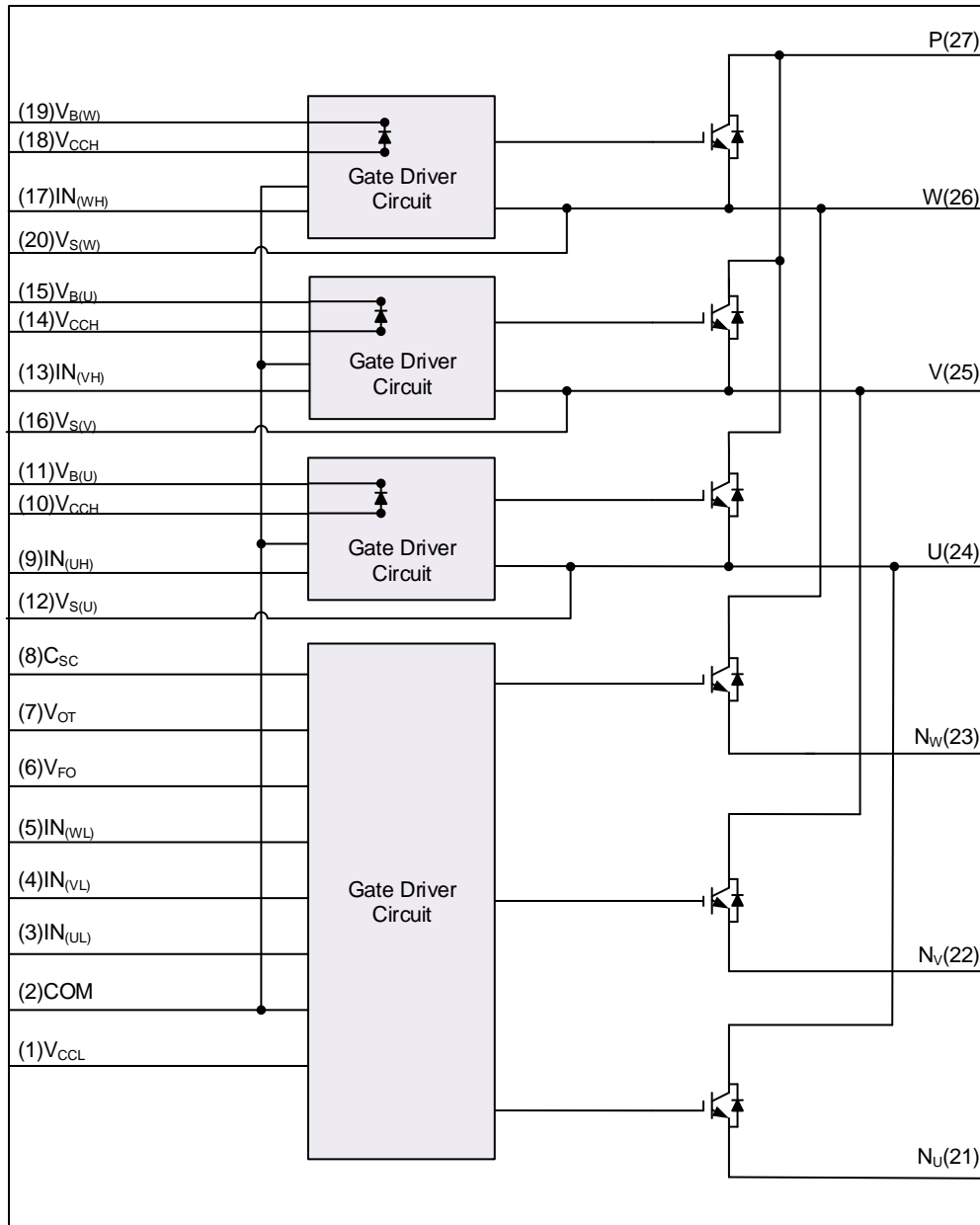

Figure 3. IPM Internal Block Diagram

Application:

- Short-circuit current protection AC 100~240Vrms class 3 phase output for low power motor control.
- Household electric appliances such as air conditioners, washing machines, refrigerators, etc..
- Low power industrial servo drives applications such as sewing machine, treadmill, etc...

MAXIMUM RATINGS ($T_j = 25^\circ\text{C}$)

INVERTER PART

Item	Symbol	Min.	Max.	Unit
Between collector to emitter voltage	V_{CES} (IGBT)	-	600	V
Supply voltage P-N	V_{PN}	-	450	V
Supply voltage (surge) P-N	V_{PN} (surge)	-	500	V
Each IGBT collector current	$\pm I_C$ ($T_C = 25^\circ\text{C}$)	-	20	A
Each IGBT collector current (peak)	$\pm I_{CP}$ ($T_C = 25^\circ\text{C}$, pulse)	-	40	A
Collector dissipation	P_C ($T_C = 25^\circ\text{C}$, per one chip)	-	78	W
Junction temperature	T_j (Note 1)		+150	$^\circ\text{C}$

Note 1: Power chip in IPM is qualified for 175°C operation. But overall junction temperature should be limited by $T_j \leq 125^\circ\text{C}$ (@ $T_c \leq 100^\circ\text{C}$) to fit long term reliability requirement.

CONTROL PART

Item	Symbol	Min.	Max.	Unit
Driver IC supply voltage	V_{CC}	-0.3	20	V
P - side floating supply voltage	$V_{B(u)S(u), B(V)S(V), B(W)S(W)}$	-0.3	20	V
Current sensing input voltage	V_{SC}	-0.3	$V_{CC}+0.3$	V
Logic input voltage	$IN_{(UH)}, IN_{(VH)}, IN_{(WH)},$ $IN_{(UL)}, IN_{(VL)}, IN_{(WL)}$	-0.3	$V_{CC}+0.3$	V
Fault output voltage	V_{FO}	-0.3	$V_{CC}+0.3$	V
Fault output current	I_{FO}	-	1	mA

TOTAL SYSTEM

Item	Symbol	Min.	Max.	Unit
Module case operating temperature	T_C (Note 2)	-20	+125	$^\circ\text{C}$
Storage temperature	T_{stg}	-40	+125	$^\circ\text{C}$
Isolation voltage (60Hz Sinusoidal, AC 1 minute, pins to heat-sink plate)	V_{iso}	-	2500	Vrms

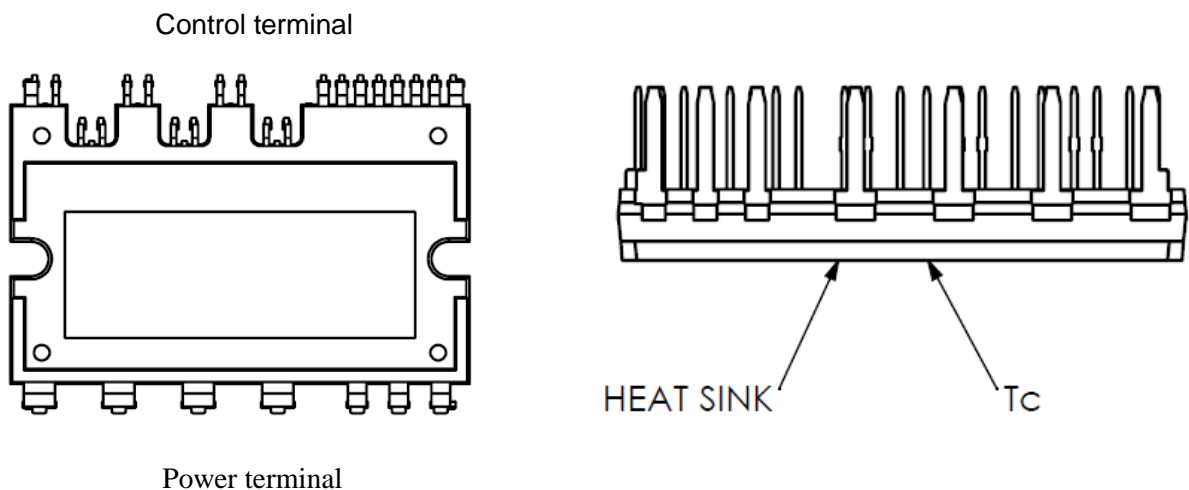

Figure 4. T_c Measurement Point

THERMAL RESISTANCE

Item	Symbol	Condition	Min.	Typ.	Max.	Unit
Junction to case thermal resistance	$R_{th(j-c)Q}$	IGBT part (1/6)	-	1.6	-	°C/W
	$R_{th(j-c)F}$	FWD part (1/6)	-	2.0	-	

ELECTRICAL CHARACTERISTICS ($T_j = 25^\circ\text{C}$)

INVERTER PART

Item	Symbol	Condition	Min.	Typ.	Max.	Unit	
Collector-emitter saturation voltage	$V_{CE(sat)}$	$V_{CC} = V_{B(U)S(U), B(V)S(V), B(W)S(W)} = 15\text{V}, I_C = 20\text{A}, V_{SC} = 0\text{V}$	$T_j = 25^\circ\text{C}$	-	1.50	-	V
FWD forward voltage drop	V_F	$T_j = 25^\circ\text{C}, -I_C = 20\text{A}$	-	1.80	-	V	
Switching times (Fig. 5)	T_{on}	$V_D = 300\text{V},$ $V_{CC} = V_{B(U), B(V), B(W)} = 15\text{V},$ $I_C = 20\text{A}, T_j = 25^\circ\text{C},$ $V_{IN} = 5\text{V} \leftrightarrow 0\text{V},$ $V_{SC} = 0\text{V}, \text{ Inductive Load}$	-	0.80	-	μS	
	$T_{c(on)}$		-	0.20	-		
	T_{off}		-	0.50	-		
	$T_{c(off)}$		-	0.15	-		
	T_{rr}		-	0.10	-		
Collector-emitter cut-off current	I_{CES}	$V_{CE} = V_{CES}$	-	-	1	mA	

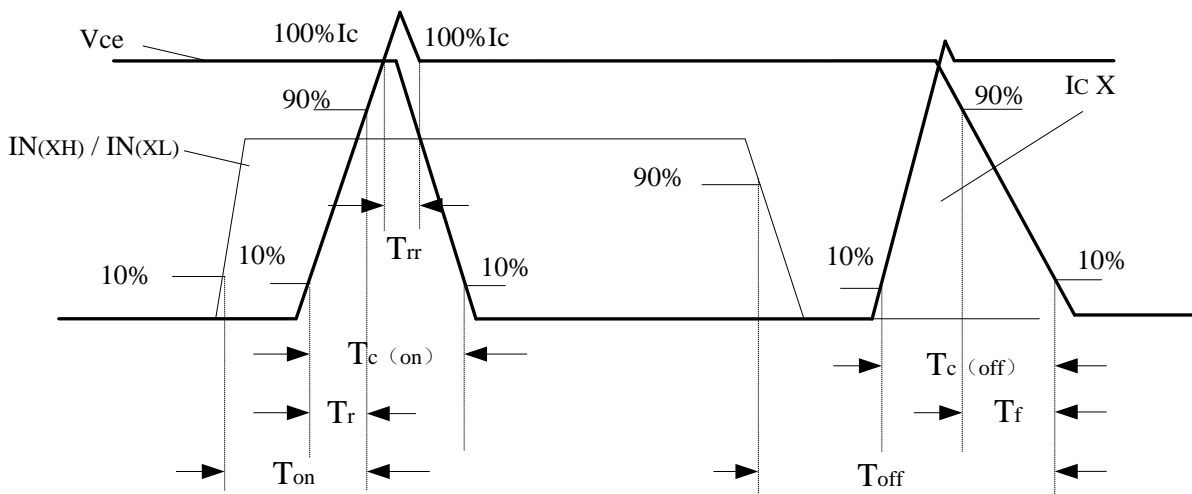

Figure 5. Switching Time Definition

CONTROL PART ($T_j = 25^\circ\text{C}$)

Item	Symbol	Condition	Min.	Typ.	Max.	Unit
$IN_{(UH, VH, WH)}, IN_{(UL, VL, WL)}$ ON threshold voltage	$V_{th(on)}$		-	-	3.0	V
$IN_{(UH, VH, WH)}, IN_{(UL, VL, WL)}$ OFF threshold voltage	$V_{th(off)}$		0.8	-	-	V
$IN_{(UH, VH, WH)}$ input bias current	$I_{IN(UH, VH, WH)(HI)}$	$V_{IN(UH, VH, WH)} = 3.3V$	-	-	660	μA
	$I_{IN(UH, VH, WH)(LO)}$	$V_{IN(UH, VH, WH)} = 0V$	-1	-	-	
$IN_{(UL, VL, WL)}$ input bias current	$I_{IN(UL, VL, WL)(HI)}$	$V_{IN(UL, VL, WL)} = 3.3V$	-	-	660	μA
	$I_{IN(UL, VL, WL)(LO)}$	$V_{IN(UL, VL, WL)} = 0V$	-1	-	-	
Quiescent V_{BS} supply current	I_{QBS}	$V_{BS}=15V, I_{IN(UH, VH, WH)}=0V$	-	70	120	μA
Quiescent VCC supply current	I_{QCC}	$V_{BS}=15V, I_{IN}=0V$	-	2	3	mA
Driver IC supply voltage	V_{CC}		13.5	15.0	16.5	V
P - side floating supply voltage	$V_{B(U, B(V), B(W))}$		13.5	15.0	16.5	V
Fault output voltage	V_{FOH}	$V_{SC}=0V$ (Note 2)	4.5	-	-	V
	V_{FOL}	$V_{SC}=1V$	-	-	0.8	V
Short circuit trip level	$V_{SC(ref)}$	$V_{CC}=15V, T_j = 25^\circ\text{C}$	0.45	0.48	0.51	V
Fault output pulse width	t_{FOD}	$C_{FOD}=33nF$ (Note 3)	60	-	-	μs
Supply Circuit Under-Voltage-Protection	UV_{CCD}	Trip level	-	11.0	-	V
	UV_{CCR}	Reset level	-	12.0	-	V
	UV_{BSD}	Trip level	-	10.5	-	V
	UV_{BSR}	Reset level	-	11.5	-	V
$IN_{(UL, VL, WL)}$ Input filter time	$t_{IN, FIL}$	$V_{IN} = 0 \text{ \& } 5V$ (Note 4)	200	300	510	ns
Temperature Output	V_{OT}	LVIC temperature= 25°C	0.55	0.65	0.75	V
		LVIC temperature= 120°C	2.45	2.55	2.65	V
Over temperature protection	OT_t	Trip level		150		$^\circ\text{C}$
	OT_{rh}	Hysteresis of trip-reset		20		$^\circ\text{C}$
VF	Bootstrap diode forward voltage	$I_f=10mA, T_j = 25^\circ\text{C}$	-	1.6	-	V
R	Limiting resistance	Individual resistor		80	-	Ohm

Note 2: V_{FO} output is open collector type, so this signal line should be pulled up to the +5V power supply with approximately 4.7K Ω

Note 3: For high side PWM, $IN_{(UH, VH, WH)}$ pulse width must be $\geq 1 \mu\text{s}$.

Input Filter Function

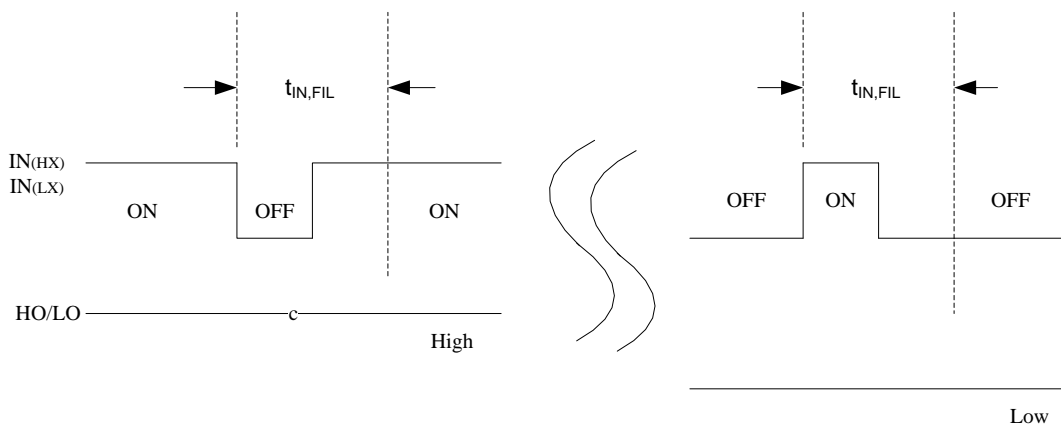

Figure 6. Input Filter Function

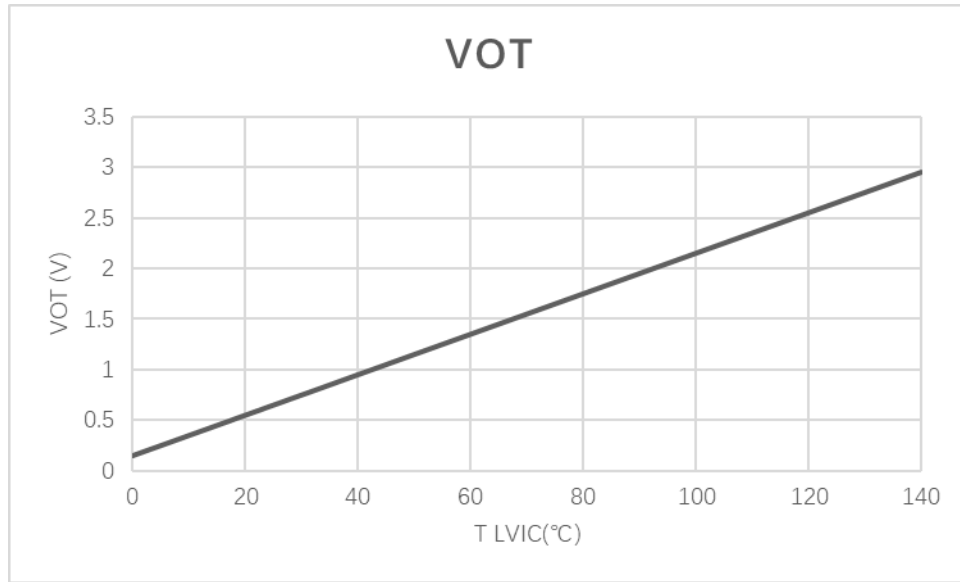

Figure 7 VOT output characteristics (typical value)

RECOMMENDED OPERATION CONDITIONS

Item	Symbol	Condition	Min.	Typ.	Max.	Unit
DC – Link Supply voltage	V_D	Applied between P-N	0	300	400	V
Driver IC supply voltage	V_{CC}	Applied between V_{CC} - COM	13.5	15.0	16.5	V
P - side floating supply voltage	V_{BS}	Applied between $V_{B(u. v. w)} - V_{S(u. v. w)}$	13.5	15.0	16.5	V
Supply voltage ripple	$\Delta V_D, \Delta V_{DB}$		-1	-	1	V/ μ s
Arm shoot-through blocking time	t_{dead}		1	-	-	μ s
PWM input frequency	f_{PWM}	$T_C \leq 100^\circ C, T_j \leq 125^\circ C$	-	0	20	kHz
Voltage for Current Sensing	V_{SEN}	Applied between $N_U, N_V, N_W - COM$ (Including Surge Voltage)	-4	-	4	V

MECHANICAL CHARACTERISTICS AND RATINGS

Item	Condition	Min.	Typ.	Max.	Unit
Mounting torque	Mounting screw: M3 Recommended 0.7 N•m	0.6	0.7	0.8	N•m
Weight	--	-	15.00	-	g
Heat-sink flatness	--	0	-	150	μ m

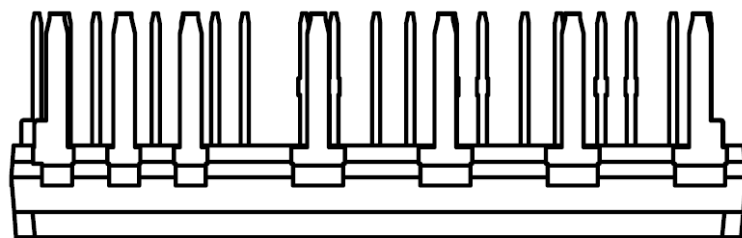

Contact to a heat sink

Figure 8 Measurement Location of Heat-sink Flatness

Input/Output Timing Diagram

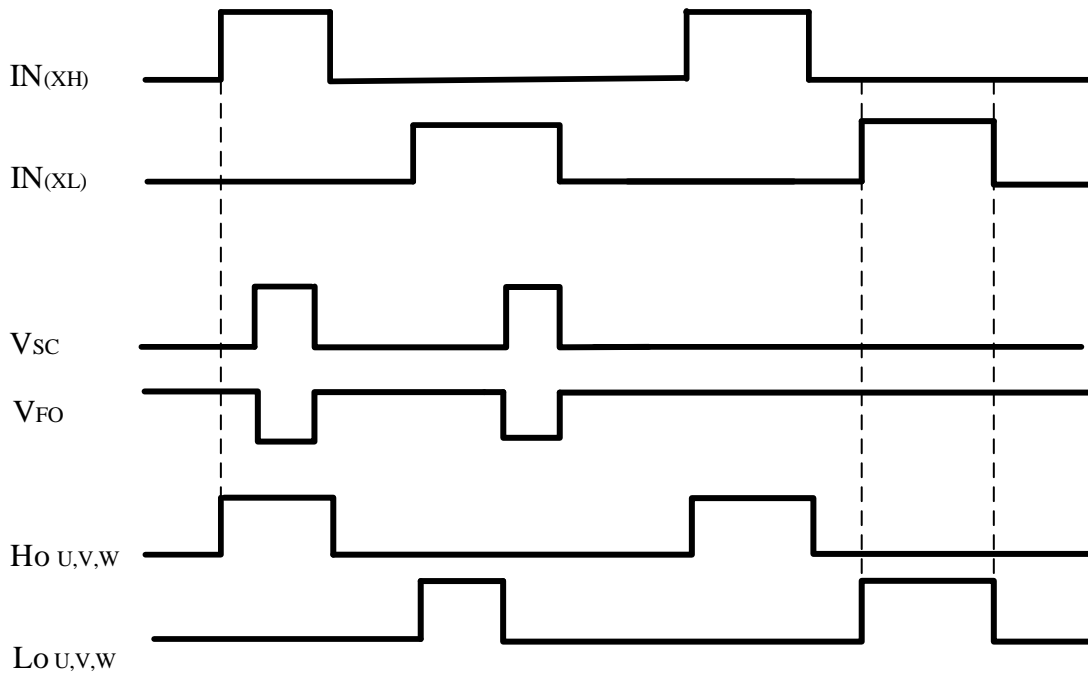
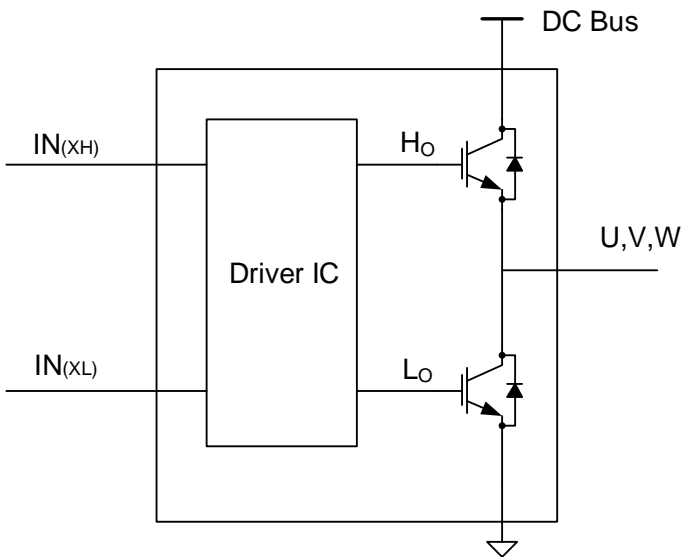

Figure 9 Input/Output Timing Diagram



V_{sc}	$IN_{(XH)}$	$IN_{(XL)}$	U, V, W
0	1	0	DC Bus
0	0	1	0
0	0	0	0
1	1	0	DC Bus
1	0	1	0

(X=U, V, W)

Figure 10 Input/Output Signal Circuit

**IPM Short-Circuit Protection Function
(N-side only with the external shunt resistor and RC filter)**

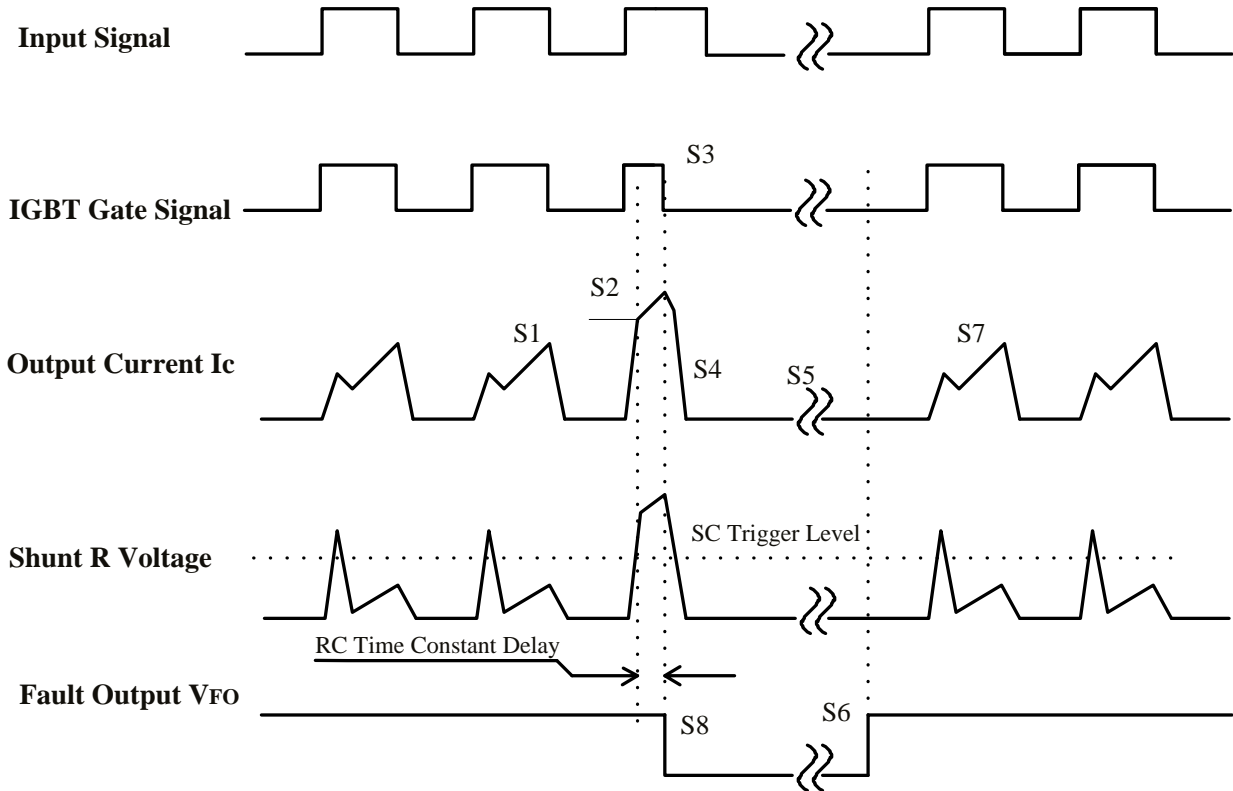

Figure 11 Timing Chart of SC Operation

- S1. The Lower-side IGBT's are controlled by input PWM signal.(Normal operation)
- S2. Short circuit event occurs and reaches the limited level. (SC protection is trigger.)
- S3. All N-side IGBT gate driving signals are disabled.
- S4. Current is cut off caused by IGBT turns OFF.
- S5. Disabled state.
- S6. Fo finishes output, but IGBT of each phase returns to normal state until inputting next ON signal(L→H).
- S7. IGBT returns for normal operation when fault state is reset.
- S8. Fault output starts once SC protection is trigger.

IPM Under-Voltage Protection Function

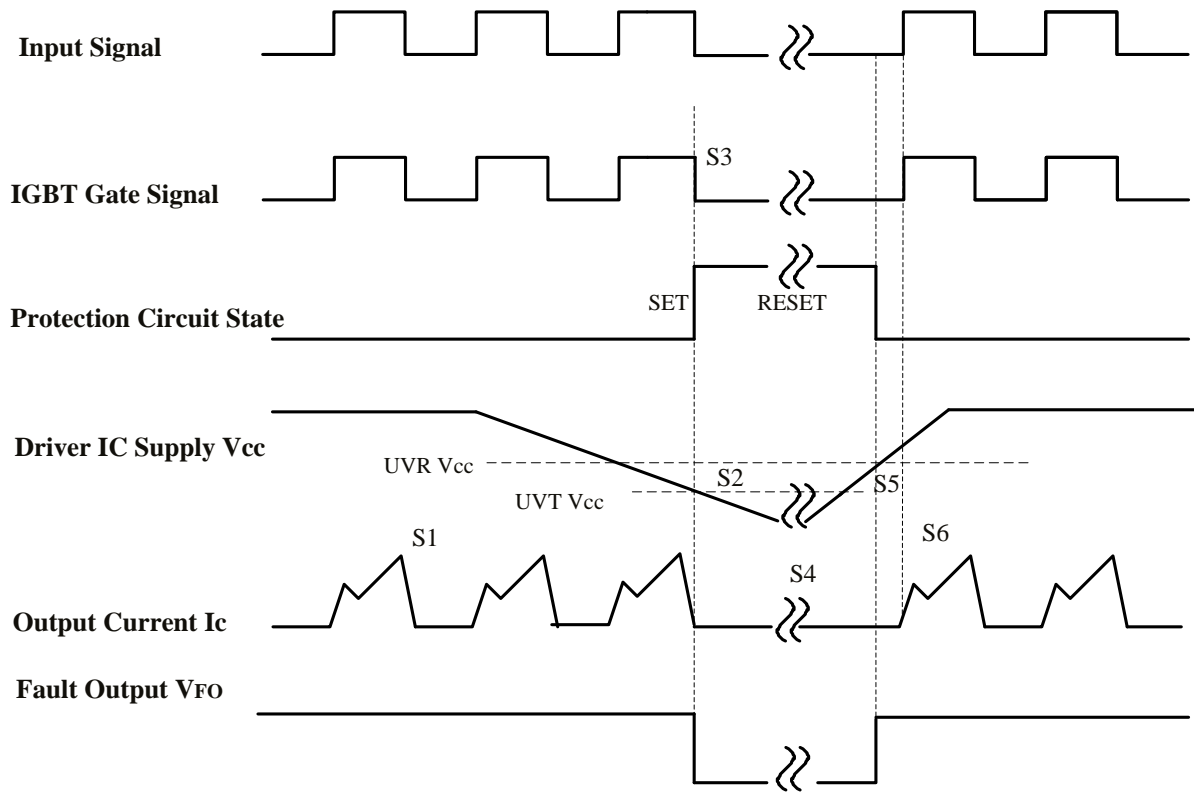

Figure 12 Timing Chart of Under-Voltage Operation

- S1. The IGBT's are controlled by input PWM signal.(Normal operation).
- S2. Under-voltage protection is trigger.
- S3. IGBT driving signals are disabled when fault condition occur.
- S4. Fault state and the period will be able to control by external capacitor value.
- S5. Under-voltage event is recovered.
- S6. IGBT returns for normal operation when fault state is reset.

IPM Over Temperature Protection Function

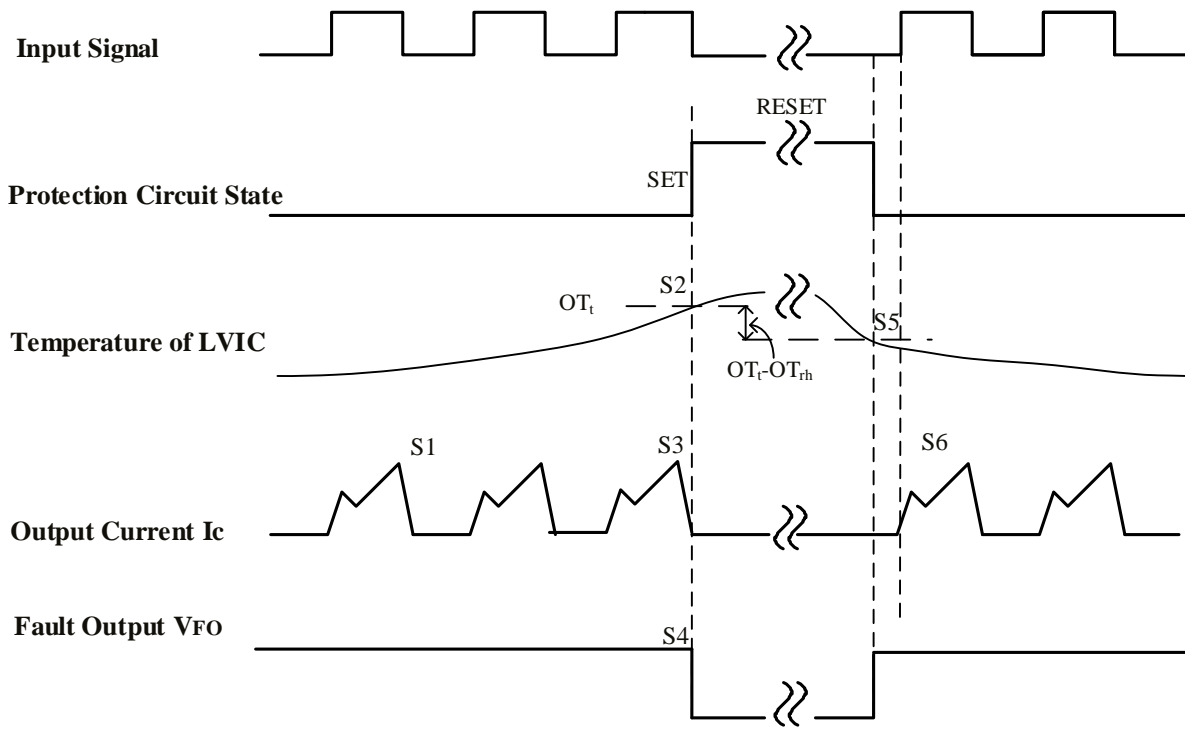

Figure 13. Timing Chart of Over Temperature Protection Operation

- S1. The IGBT's are controlled by input PWM signal.(Normal operation)
- S2. LVIC temperature exceeds over temperature trip level(OT_t).
- S3. All N-side IGBTs turn OFF in spite of control input condition.
- S4. Fo output is extended during LVIC temperature keeps over OT_t .
- S5. LVIC temperature drops to over temperature reset level.
- S6. Normal operation: IGBT turns on by next ON signal (L->H).
(IGBT of each phase can return to normal state by inputting ON signal to each phase.)

Direct Input (without Photo Coupler) Interface Example

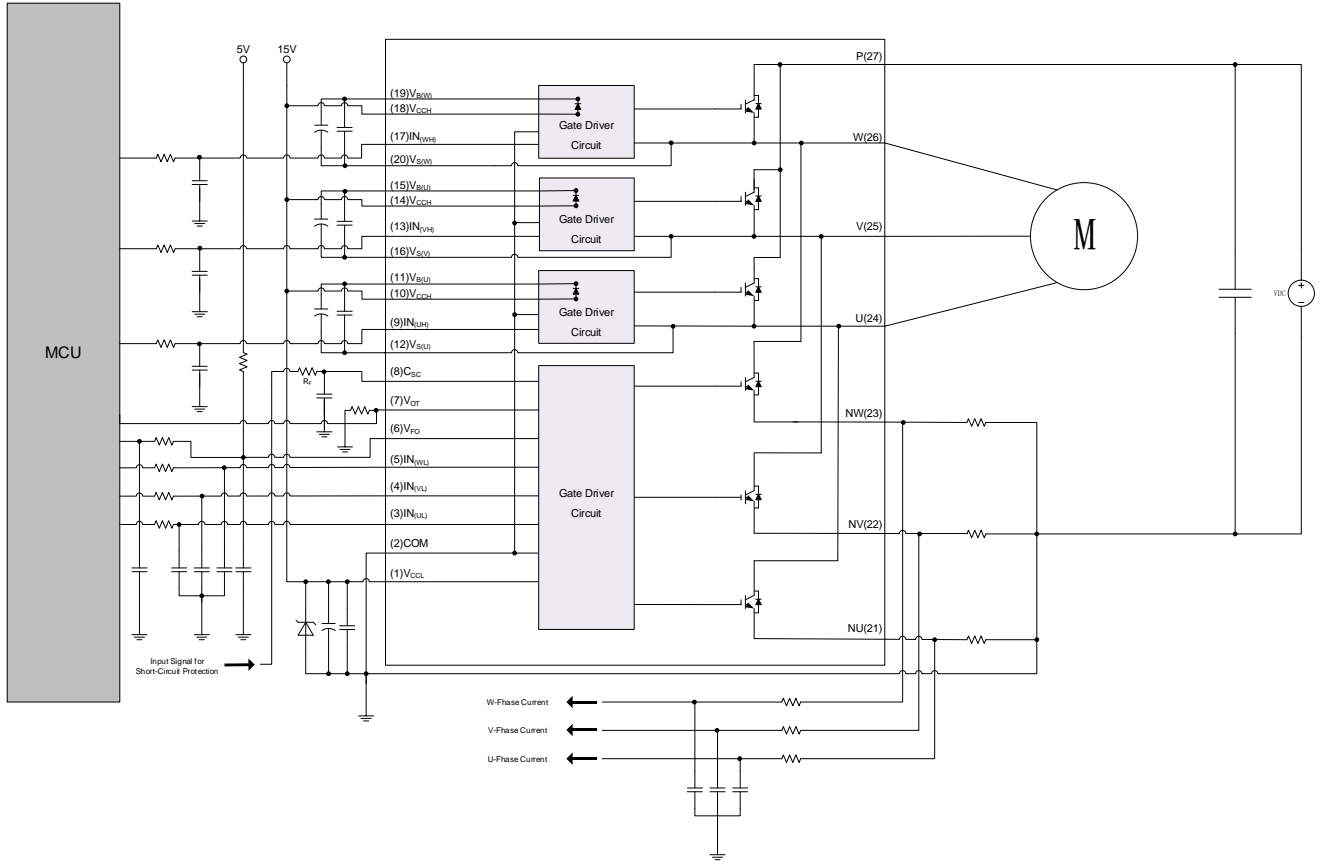

Figure 14 Typical Application Circuit Interface Example without Photo-Coupler

Current Sense Scheme

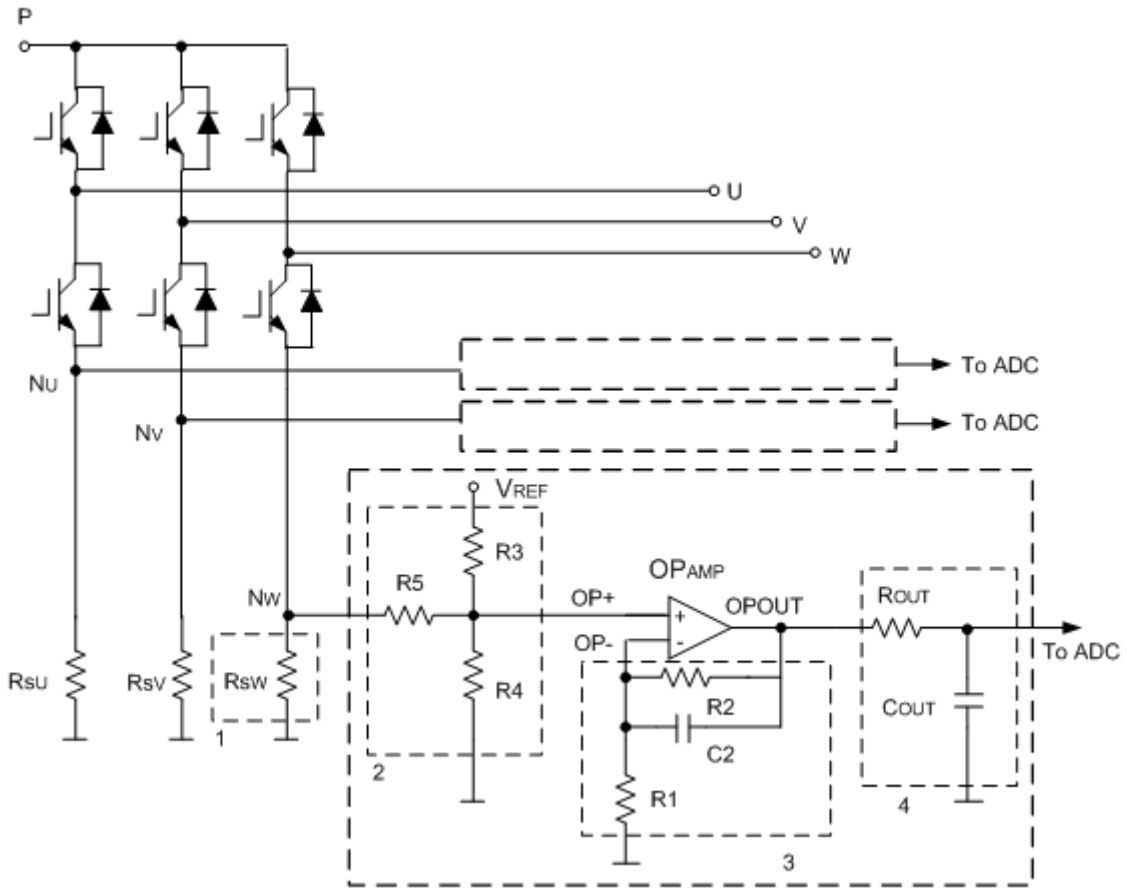

Figure 15 Current Sense Scheme

Precautions on Electrostatic Electricity

- (1) Operators must wear anti-static clothing and conductive shoes (or a leg or heel strap).
- (2) Operators must wear a wrist strap grounded to earth via a resistor of about 1 M Ω .
- (3) Soldering irons must be grounded from iron tip to earth, and must be used only at low voltages.
- (4) If the tweezers you use are likely to touch the device terminals, use anti-static tweezers and in particular avoid metallic tweezers. If a charged device touches a low-resistance tool, rapid discharge can occur. When using vacuum tweezers, attach a conductive chucking pat to the tip, and connect it to a dedicated ground used especially for anti-static purposes (suggested resistance value: 10⁴ to 10⁸ Ω).
- (5) Do not place devices or their containers near sources of strong electrical fields (such as above a CRT).
- (6) When storing printed circuit boards which have devices mounted on them, use a board container or bag that's protected against static charge. To avoid the occurrence of static charge or discharge due to friction, keep the boards separate from one other and do not stack them directly on top of one another.
- (7) Ensure, if possible, that any articles (such as clipboards) which are brought to any location where the level of static electricity must be closely controlled are constructed of anti-static materials.
- (8) In cases where the human body comes into direct contact with a device, be sure to wear anti-static finger covers or gloves (suggested resistance value: 10⁸ Ω or less).
- (9) Equipment safety covers installed near devices should have resistance ratings of 10⁹ Ω or less.
- (10) If a wrist strap cannot be used for some reason, and there is a possibility of imparting friction to devices, use an ionizer.

CONFIDENTIALITY OBLIGATIONS:

This document contains sensitive information and classified “**CONFIDENTIAL**”.

Please make sure you should comply with the following security rules at all times

Do not copy or reproduce all or part of this document and further copies can be provided on a “need to know basis”, please contact your local Starpower sales office.

PLEASE READ CAREFULLY:

Starpower reserve the right to make changes, corrections, modifications or improvements, to this document, and the products and services described herein at anytime, without notice. Starpower assumes no liability whatsoever relating to the choice, selection or use of the Starpower products and services described herein.

And purchasers are solely responsible for the choice, selection and use of the Starpower products and services described herein, No license, express or implied, to any intellectual property rights is granted under this document. If any part of this document refers to any third party products or services it shall not be deemed a license grant by Starpower for the use of such third party products or services, or any intellectual property contained therein or considered as a warranty covering the use in any manner whatsoever of such third party products or services or any intellectual property contained therein. Unless otherwise set forth in Starpower terms and conditions of sale Starpower disclaims any express or implied warranty with respect to the use and/or sale of Starpower products including without limitation implied warranties of merchantability, fitness for a particular purpose (and their equivalents under the laws of any jurisdiction), or infringement of any patent, copyright or other intellectual property right. Unless expressly approved in writing by an authorized Starpower representative, Starpower products are not recommended, authorized or warranted for use in military, air craft, space, life saving, or life sustaining applications, nor in products or systems where failure or malfunction may result in personal injury, death, or severe property or environmental damage.

Information in this document supersedes and replaces all information previously supplied.

www.powersemi.cc