

DOSEMI

SiC MOSFET

DM400S12TDRB

1200V/40mΩ SiC Mosfet without Diode

General Description

DOSEMI MOSFET Power Discrete provides ultra low conduction loss as well as low switching loss. They are designed for the applications such as hybrid and electric vehicle.

Features

- SiC power MOSFET
- Low $R_{DS(on)}$
- Low inductance case avoid oscillations
- ROHS

Typical Applications

- Automotive application
- Hybrid and electric vehicle
- Inverter for motor drive

Equivalent Circuit Schematic

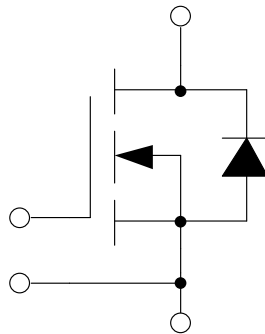

Type	Package	Marking	Shipping
DM400S12TDRB	TO-247PLUS-4L	DM400S12TDRB	30Units/Tube

Absolute Maximum Ratings $T_C=25^\circ\text{C}$ unless otherwise noted**Mosfet**

Symbol	Description	Value	Unit
V_{DSS}	Drain-Source Voltage	1200	V
V_{GSSmax}	Gate-Source Voltage	-8/+22	V
V_{GSSop}	Gate-Source Voltage	-4/+15	V
I_D	Drain Current @ $T_{vj}=175^\circ\text{C}$	64	A
P_D	Maximum Power Dissipation @ $T_{vj}=175^\circ\text{C}$	268	W

Body Diode

Symbol	Description	Value	Unit
I_F	Source Current @ $T_{vj}=175^\circ\text{C}$	50	A

Discrete

Symbol	Description	Values	Unit
T_{vjop}	Operating Junction Temperature	-40 to +175	$^\circ\text{C}$
T_{STG}	Storage Temperature Range	-55 to +150	$^\circ\text{C}$
T_S	Soldering Temperature, 1.6mm from case for 10s	260	$^\circ\text{C}$

Mosfet Characteristics $T_C=25^\circ\text{C}$ unless otherwise noted

Symbol	Parameter	Test Conditions	Min.	Typ.	Max.	Unit
$R_{DS(on)}$	Static Drain-Source On-Resistance	$I_D=34\text{A}, V_{GS}=15\text{V}, T_{vj}=25^\circ\text{C}$		40.0		m Ω
		$I_D=34\text{A}, V_{GS}=15\text{V}, T_{vj}=150^\circ\text{C}$		50.5		
		$I_D=34\text{A}, V_{GS}=15\text{V}, T_{vj}=175^\circ\text{C}$		55.2		
$V_{GS(th)}$	Gate-Source Threshold Voltage	$I_D=8.7\text{mA}, V_{DS}=V_{GS}, T_{vj}=25^\circ\text{C}$		2.75		V
I_{DSS}	Drain-Source Leakage Current	$V_{DS}=V_{DSS}, V_{GS}=0\text{V}, T_{vj}=25^\circ\text{C}$			100	μA
I_{GSS}	Gate-Source Leakage Current	$V_{GS}=V_{GSS}, V_{DS}=0\text{V}, T_{vj}=25^\circ\text{C}$			200	nA
R_{Gint}	Internal Gate Resistance			2.05		Ω
C_{iss}	Input Capacitance	$V_{GS}=0\text{V}, V_{DS}=800\text{V}, f=100\text{kHz}$		3.13		nF
C_{oss}	Output Capacitance			116		pF
C_{rss}	Reverse Transfer Capacitance			6.83		pF
Q_g	Total Gate Charge	$I_D=34\text{A}, V_{DS}=800\text{V}, V_{GS}=-4/+15\text{V}$		86.6		nC
$t_{d(on)}$	Turn-On Delay Time	$V_{DS}=800\text{V}, I_D=34\text{A}, R_G=5.1\Omega, L_S=40\text{nH}, V_{GS}=-4/+15\text{V}, T_{vj}=25^\circ\text{C}$		23		ns
t_r	Rise Time			9		ns
$t_{d(off)}$	Turn-Off Delay Time			34		ns
t_f	Fall Time			31		ns
E_{on}	Turn-On Switching Loss			0.41		mJ
E_{off}	Turn-Off Switching Loss			0.34		mJ
$t_{d(on)}$	Turn-On Delay Time	$V_{DS}=800\text{V}, I_D=34\text{A}, R_G=5.1\Omega, L_S=40\text{nH}, V_{GS}=-4/+15\text{V}, T_{vj}=150^\circ\text{C}$		22		ns
t_r	Rise Time			9		ns
$t_{d(off)}$	Turn-Off Delay Time			38		ns
t_f	Fall Time			30		ns
E_{on}	Turn-On Switching Loss			0.42		mJ
E_{off}	Turn-Off Switching Loss			0.35		mJ
$t_{d(on)}$	Turn-On Delay Time	$V_{DS}=800\text{V}, I_D=34\text{A}, R_G=5.1\Omega, L_S=40\text{nH}, V_{GS}=-4/+15\text{V}, T_{vj}=175^\circ\text{C}$		22		ns
t_r	Rise Time			9		ns
$t_{d(off)}$	Turn-Off Delay Time			39		ns
t_f	Fall Time			30		ns
E_{on}	Turn-On Switching Loss			0.43		mJ
E_{off}	Turn-Off Switching Loss			0.35		mJ

Body Diode Characteristics $T_C=25^\circ\text{C}$ unless otherwise noted

Symbol	Parameter	Test Conditions	Min.	Typ.	Max.	Unit
V_{SD}	Diode Forward Voltage	$I_S=16\text{A}, V_{GS}=-4\text{V}, T_{vj}=25^\circ\text{C}$		4.35		V
		$I_S=16\text{A}, V_{GS}=-4\text{V}, T_{vj}=175^\circ\text{C}$		3.85		

Discrete Characteristics $T_C=25^\circ\text{C}$ unless otherwise noted

Symbol	Parameter	Min.	Typ.	Max.	Unit
R_{thJC}	Junction-to-Case (per Mosfet)		0.507	0.558	K/W

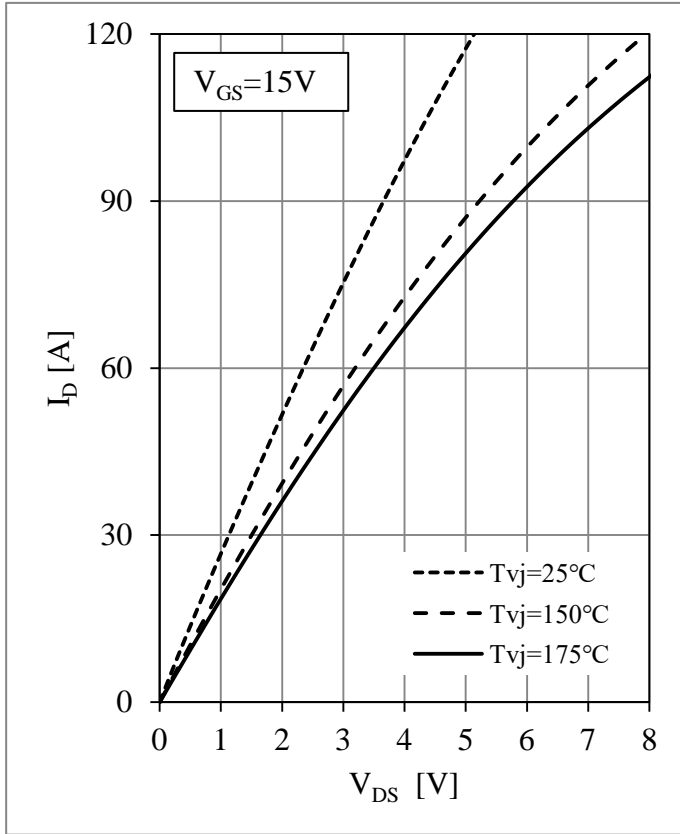

Fig 1. MOSFET Output Characteristics

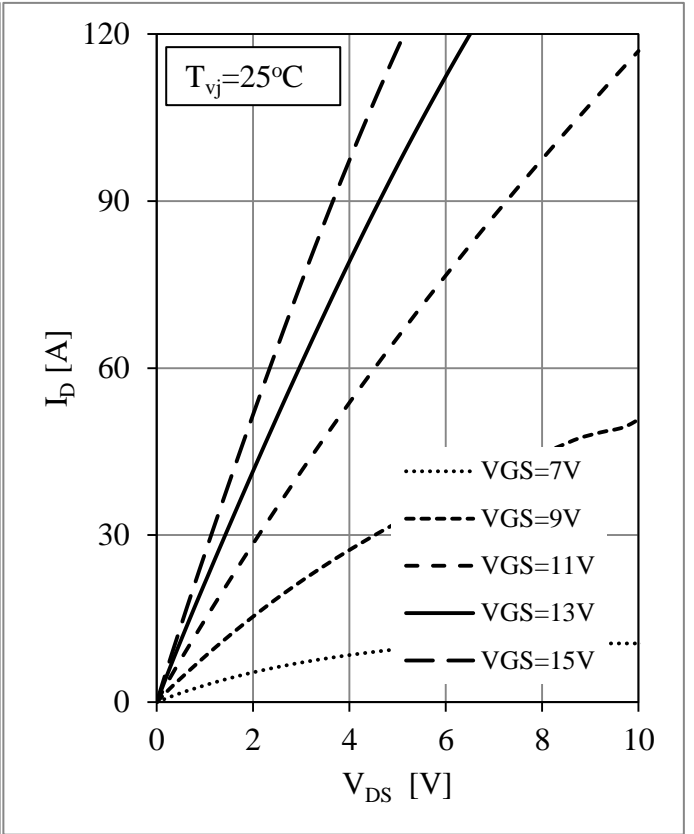

Fig 2. MOSFET Output Characteristics

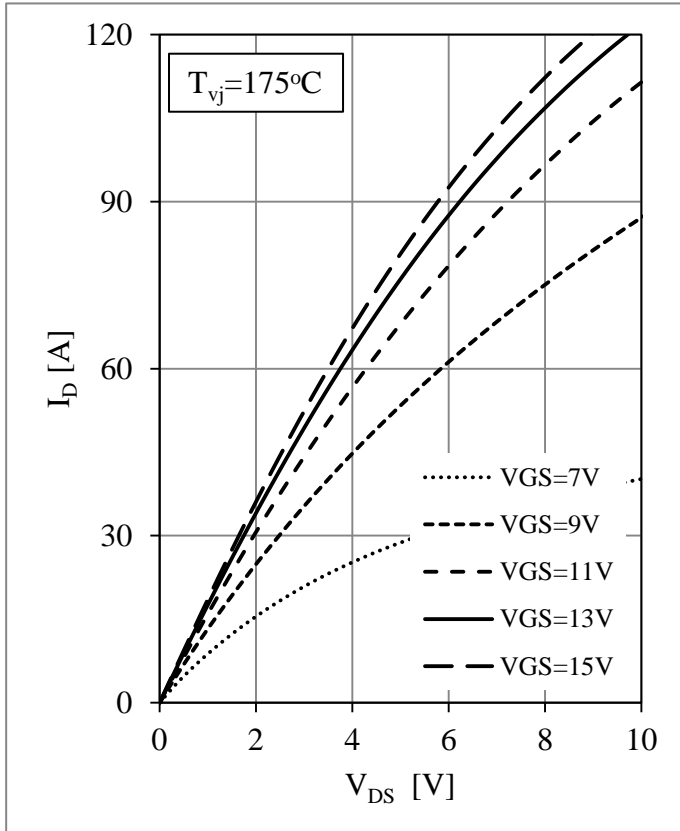

Fig 3. MOSFET Output Characteristics

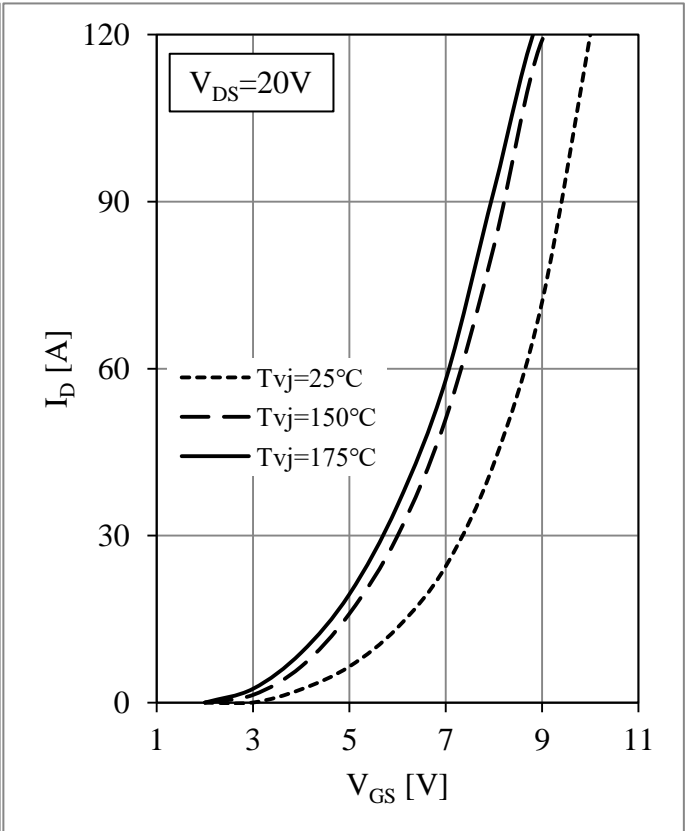

Fig 4. MOSFET Transfer Characteristics

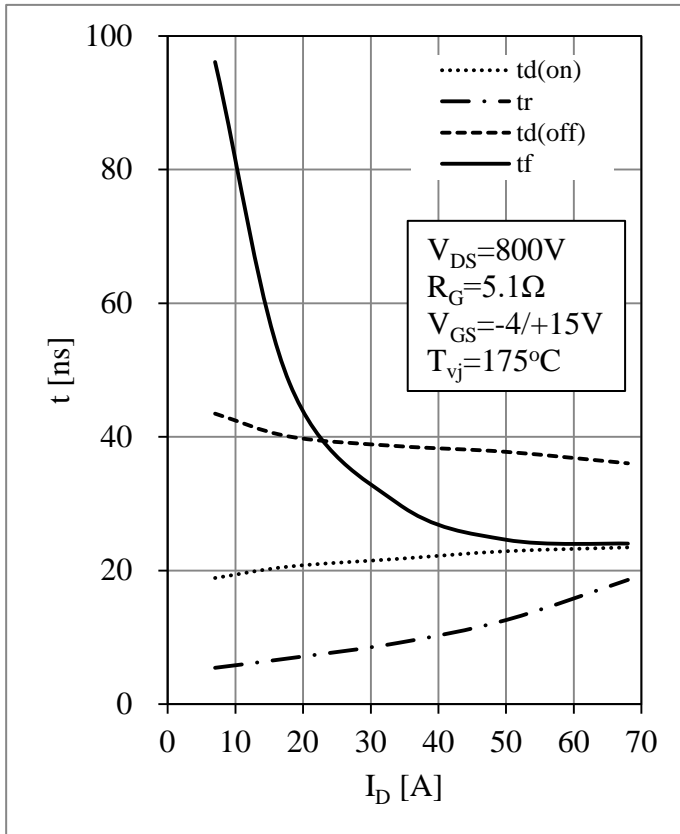

Fig 5. MOSFET Switching Times as. I_D

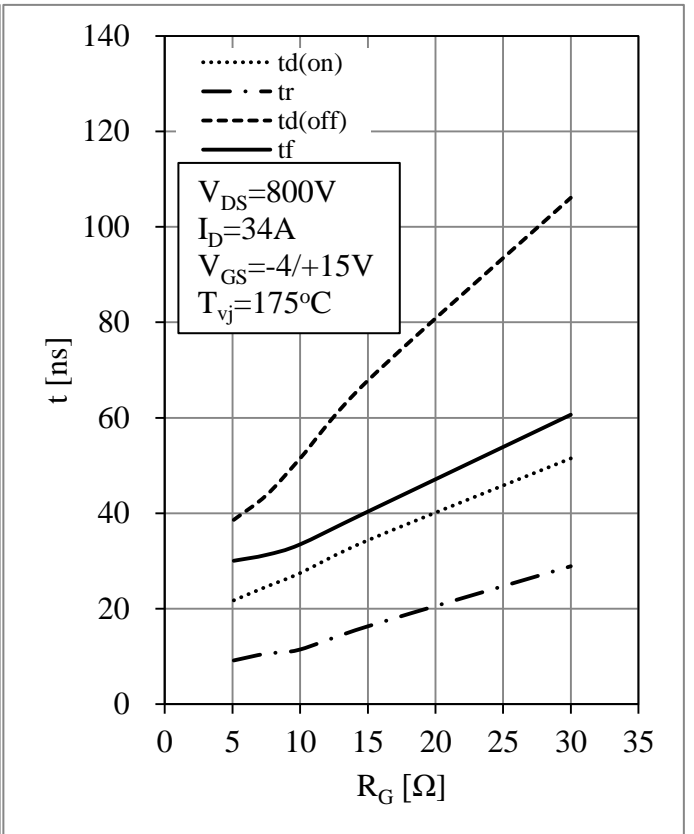

Fig 6. MOSFET Switching Times as. R_G

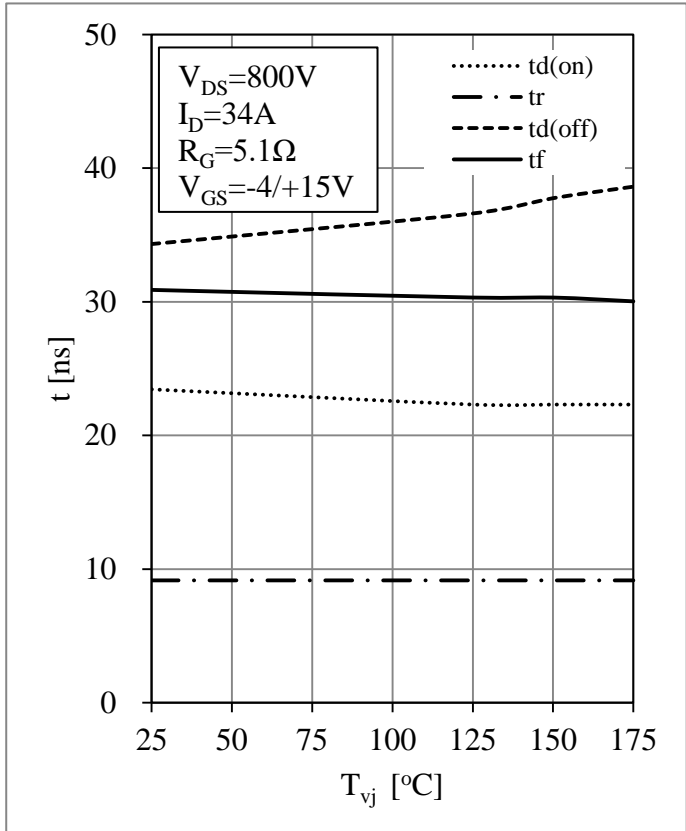

Fig 7. MOSFET Switching Times vs. T_{vj}

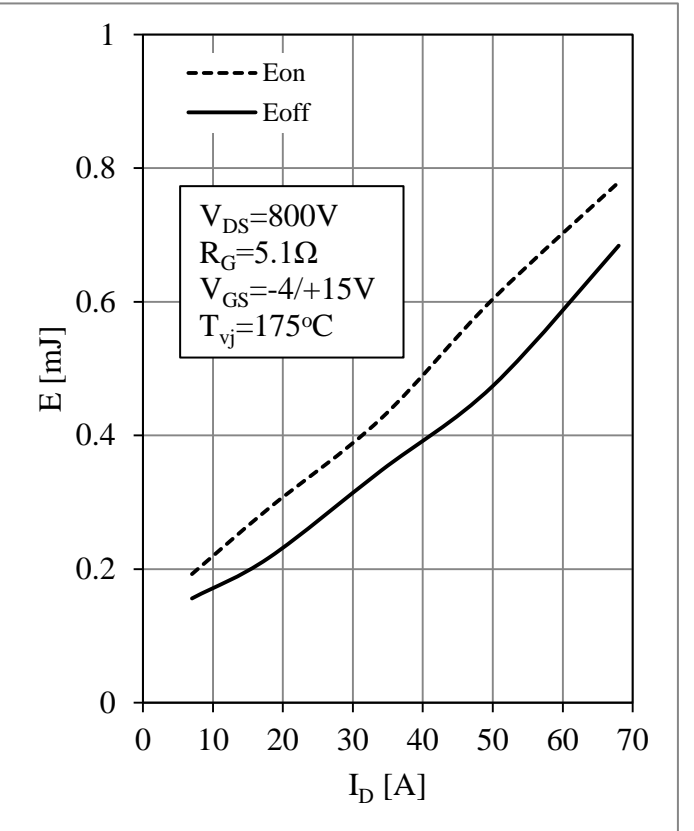

Fig 8. Switching Energy Loss vs. I_D

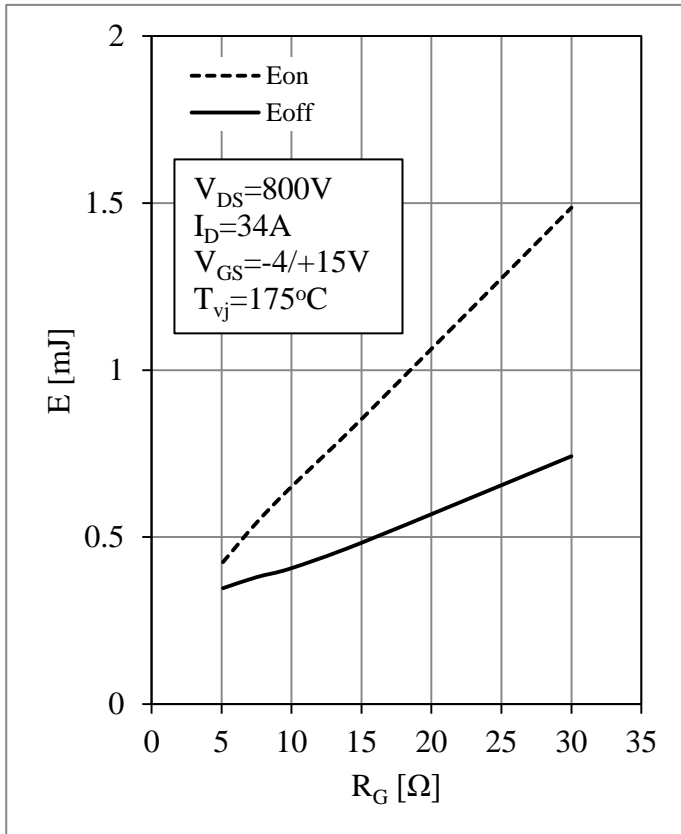

Fig 9. Switching Energy Loss vs. R_G

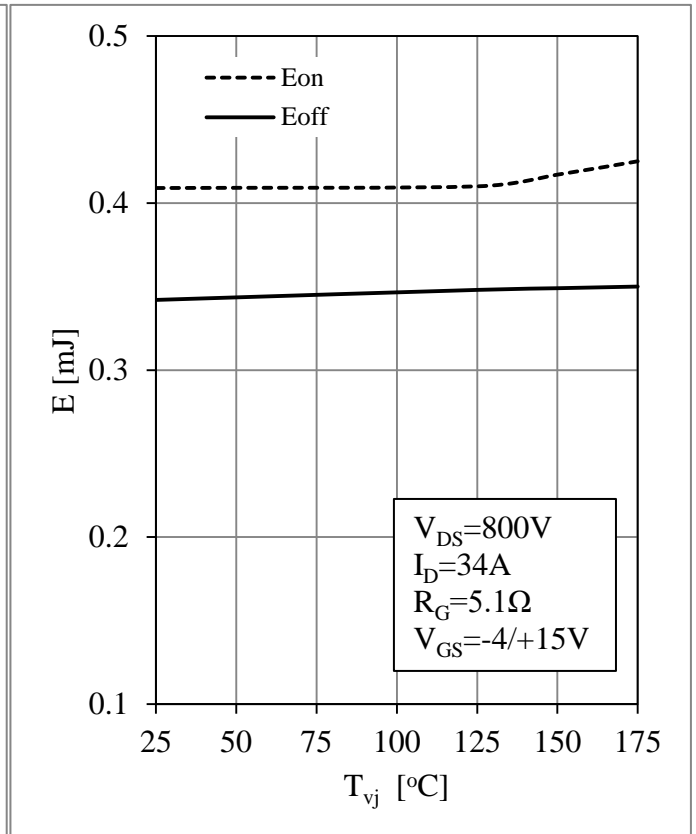

Fig 10. Switching Energy Loss vs. T_{vj}

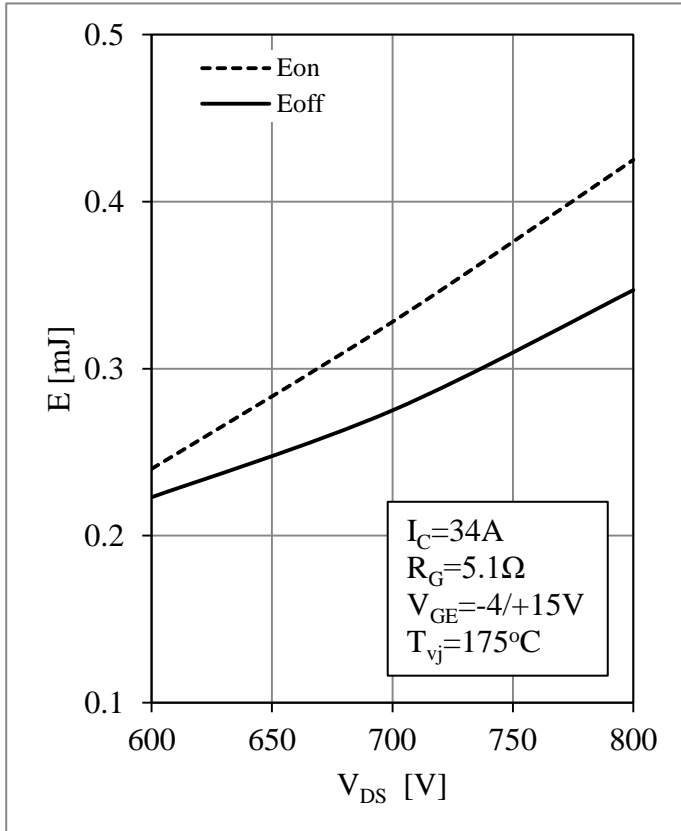

Fig 11. Switching Energy Loss vs. V_{DS}

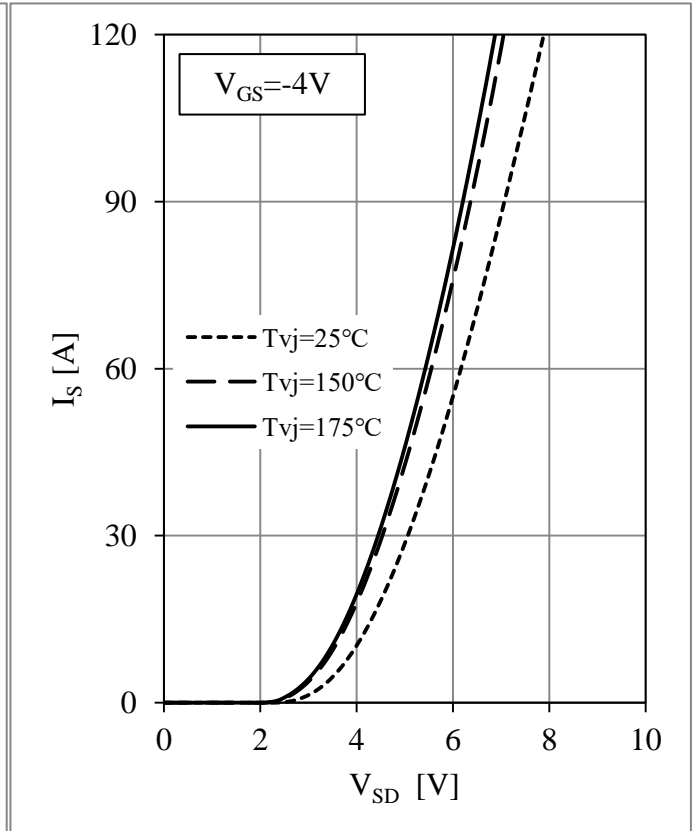

Fig 12. Body Diode Characteristics

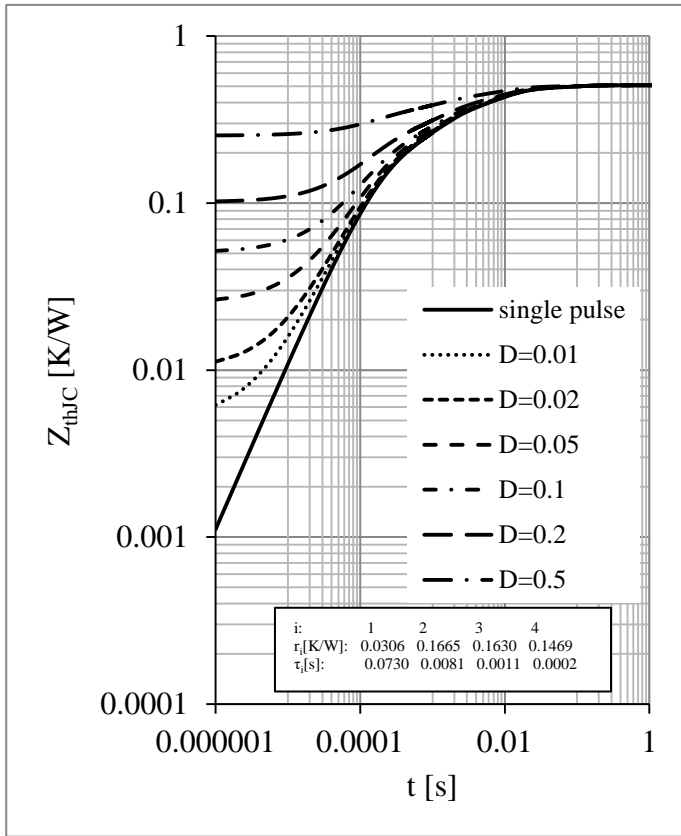
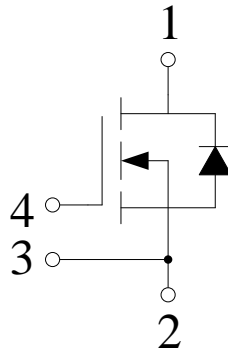

Fig 13. MOSFET Transient Thermal Impedance

Circuit Schematic



Package Dimensions

Dimensions in Millimeters

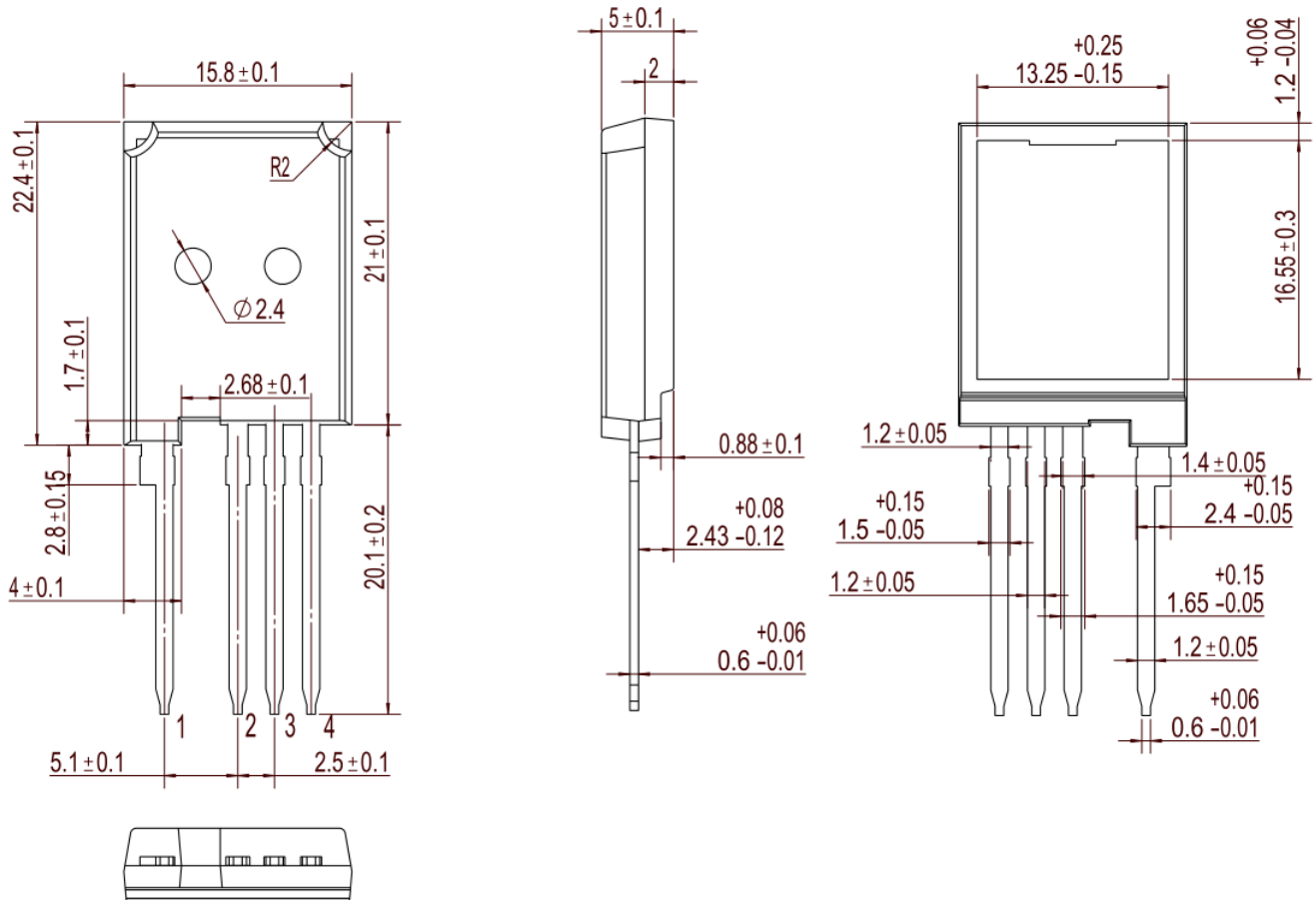

Terms and Conditions of Usage

The data contained in this product datasheet is exclusively intended for technically trained staff. you and your technical departments will have to evaluate the suitability of the product for the intended application and the completeness of the product data with respect to such application.

This product data sheet is describing the characteristics of this product for which a warranty is granted. Any such warranty is granted exclusively pursuant the terms and conditions of the supply agreement. There will be no guarantee of any kind for the product and its characteristics.

Should you require product information in excess of the data given in this product data sheet or which concerns the specific application of our product, please contact the sales office, which is responsible for you (see www.powersemi.cc), For those that are specifically interested we may provide application notes.

Due to technical requirements our product may contain dangerous substances. For information on the types in question please contact the sales office, which is responsible for you.

Should you intend to use the Product in aviation applications, in health or live endangering or life support applications, please notify.

If and to the extent necessary, please forward equivalent notices to your customers.
Changes of this product data sheet are reserved.